

CUPOWER

BORN TO BE LIGHT.



Instruction manual PUSH DIM

Content

1. Operating conditions and operation (DT6)	3
1.1 For all drivers produced until 09/2022	3
1.2 For all drivers produced from 10/2022	3
2. Wiring diagrams (DT6)	4
3. Operating conditions and operation (DT8)	5
3.1 Additional information	5
3.2 Push operation in DT8 Tunable White mode	5
4. Wiring diagrams (DT8)	8
4.1 General	8
4.2 Special (RD CCCI Series)	9
5. Spike protector	9
5.1 Background	9
5.2 Electrical Data	9
5.3 Dimensions	10
6. Technical Restrictions	10
7. CAUTION	11

1. Operating conditions and operation (DT6)

1.1 For all drivers produced until 09/2022

- Switch driver output ON/OFF: short-press (0,1...0,5 s).
- Dim driver up/down: long-press (> 0,5 s). The dimming direction is changed with each long-press.
- Reset: Long-press when driver output is OFF. Driver switch on at 1% and fade up until the switch is released.
- Synchronization: Long-press (> 5 s), short-press (0,1-0,5 s) and long-press (> 5 s).
- Definition: short-press: 0.1...0,5 s, long-press: > 0,5 s.
- Installation: maximum 20 drivers and cable length of 25 meters for one push-dim switch.

1.2 For all drivers produced from 10/2022

- Switch driver output ON/OFF: short-press (0,1...0,5 s).
- Dim driver up/down: long-press (> 0,5 s). The dimming direction is changed with each long-press.
- Default level setting: double click when the output is on.
- Delete the default level: double click when the output is off.
- Mains power on level: the power on level is last power off level.
- Short press turn on level: default level or last output level (if no default level defined).
- Fading up from minimum level: long press when output is off.
- Reset: Long-press when driver output is OFF. Driver switch on at 1% and fade up until the switch is released.

- Synchronization: Long-press (> 5 s), short-press (0,1...0,5 s) and long-press (> 5 s).
- Definition: short-press: 0,1...0,5 s, long-press: > 0,5 s.
- Installation: maximum 20 drivers and cable length of 25 meters for one push-dim switch.

2. Wiring diagrams (DT6)

In case of operating only one driver connect to PUSH-DIM switch or drivers wiring in parallel, please use a Spike Protector (e.g. XZ-DALI-A).

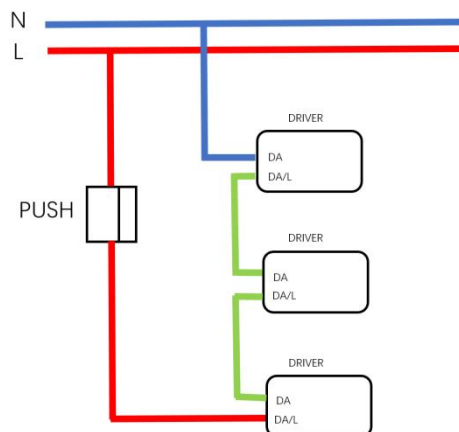
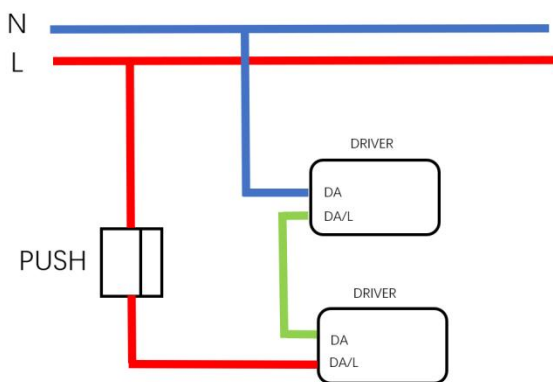
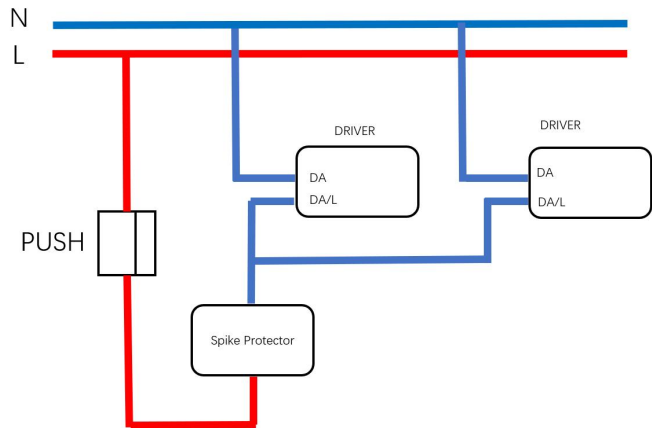
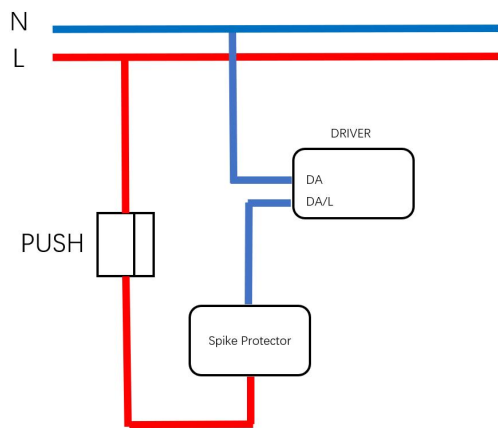

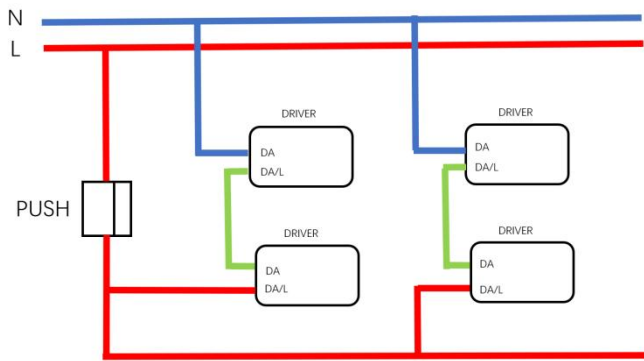

3. Operating conditions and operation (DT8)

3.1 Additional information

- The product works in DALI mode by default and is enabled in PUSH mode by pressing and holding the Push-DIM button for more than 1 s.
- The PUSH mode can be switched to DALI mode by means of any valid DALI command.

3.2 Push operation in DT8 Tunable White mode

Working mode

- Mode 1: If the device has preset brightness or color temperature settings, it will restore the state (brightness value/color temperature value/off state) from the last shutdown when powered on. Pressing the PUSH-DIM switch briefly while the light is on will execute the preset color temperature and brightness.
- Mode 2: If the device has no preset brightness/color temperature, it will restore the state (brightness value/color temperature value/light off) from the last power-off event when power-up. Pressing the PUSH-DIM switch briefly while the light is on will restore the color temperature and brightness settings from the last light-off.

Push-DIM operation

- Short press: A button press < 0.5 s is a short press, to turn the light on/off once.
- Long press: button press > 0.5 s for long press, when long pressed the brightness will adjust upwards from the current value to 100% and hold, long press again, after holding for 4 s it will adjust downwards from 100% to 1% and hold, long press again, after holding for 4 s it will adjust upwards from 1% to 100% and hold until the button is released. The ECG fades upwards each time it is switched on and changes direction each time it is long pressed.
- Double-click: two consecutive short presses with an interval of < 0.4 s. Double-click when the light is on to save the current brightness value, the ECG enters brightness mode 1, the light flashes twice and returns to its previous brightness as a reminder. When in standby (Push-DIM short press to switch off the light) double click PUSH-DIM button to delete the current brightness value, the ECG enters working brightness mode 2 and the light will adjust upwards from 1% to 100% and hold as a reminder.

Push-CCT operation

- Short press: A button press < 0.5 s is a short press. When turning on the light, the color temperature adjusts through 9 steps from coolest to warmest. Each short press moves one step toward warmer tones. At the warmest setting, a short press returns to the coolest color temperature. When turning off the light, short presses have no effect.
- Long press: button press > 0.5 s for long press. Holding the button for over 0.5 s enables stepless adjustment of the light color. When powering on for the first time,

a long press adjusts toward warmer tones. If the initial color temperature is already the warmest setting, a long press adjusts toward cooler tones. Each long press changes the adjustment direction. It takes 5 s to cycle from the coldest to the warmest setting. Once adjusted to the warmest or coldest setting, the color temperature will remain constant. When turning off the lights, a long press of Push-CCT has no effect.

- Double-click: two consecutive short presses with an interval of < 0.4 s can switch modes. Double-click when the light is on to save the current color temperature value as a preset and the ECG enters working mode 1. If saved successfully, the lamp's color temperature will revert to its previous setting after 2 flashes, with brightness remaining unchanged. Conversely, double-clicking while the light is off (Push-DIM short press to switch off the light) will delete the previously saved color temperature value and the ECG will enter working mode 2. After flashing twice, the light returns to the off state, indicating successful deletion.

Synchronize

- In a system where a single Push button controls multiple drivers, the drivers may exhibit asynchronous lamp states. They can be synchronized again. To this end, the following procedure must be followed: Long-press the PUSH-DIM button for more than 0.5 s; this will turn on the lights that are off and keep the ones that are already on. Then perform a short press; this will turn off all lights and put them into a synchronized state.
- After executing the Push-DIM "long press-short press" combination command, the lights in the system will synchronously turn off. To achieve synchronized brightness

or color temperature, an additional action must be performed after the “long press-short press” sequence. There are three options available here:

Brightness Synchronization to Mode 1: After performing a “long press - short press” sequence, hold down Push-DIM to fade to the target brightness, then double-click Push-DIM to save the brightness value.

Brightness Synchronization to Mode 2: After performing a “long press - short press” combination, double-click Push-DIM to clear the brightness value and synchronize the output to maximum brightness.

Color Temperature Synchronization to Mode 2: After performing the “long press - short press” combination, double-click Push-CCT to clear the color temperature value. Upon turning on the light, it will synchronize to the default color temperature, which is the intermediate color temperature.

4. Wiring diagrams (DT8)

PUSH switch connection in the DT8 driver

4.1 General

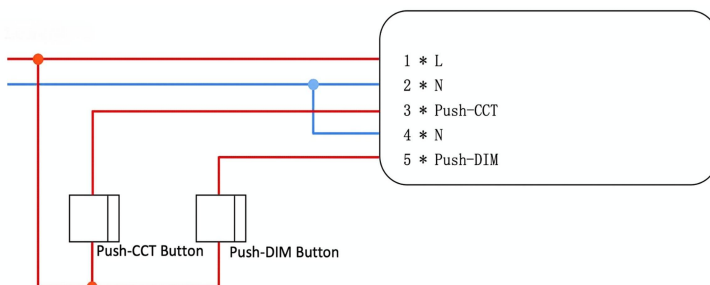

4.2 Special (RID CCCI Series)

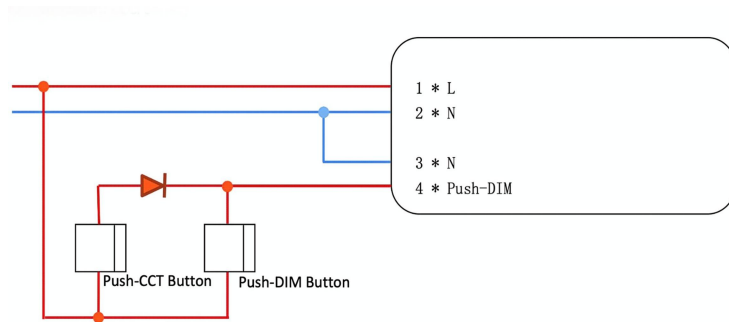

5. Spike protector

5.1 Background

The high voltage spike on PUSH-DIM wiring has negative impact to the DALI circuit. A resistor in series with the PUSH-DIM button can damp the oscillation and limit the current.

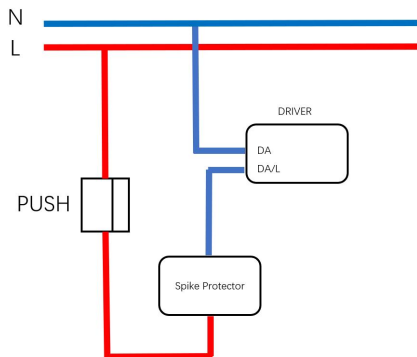

5.2 Electrical Data

Input voltage: 230V, 50/60Hz

Input voltage range: 0...300Vac

Resistance: 200...300 OHM at room temperature

Operating temperature range: -20...65 C

5.3 Dimensions

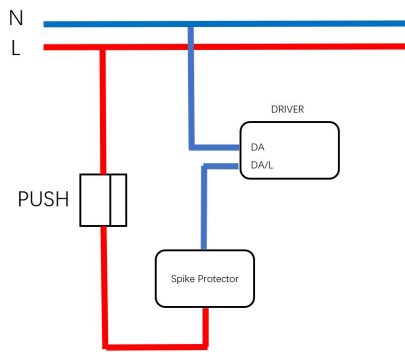

6. Technical Restrictions

Electronic devices can be damaged by high voltage. This has to be considered during the routine testing of the luminaires in production.

To avoid spikes from switches please consider devices with debounced switches. For keeping several luminaires synchronized we recommend DALI repeater in larger applications.

According to IEC 60598-1 Annex Q (informative only!) or ENEC 303-Annex A, each luminaire should be submitted to an insulation test with 500VDC for 1 second. This test voltage should be connected between the interconnected phase and neutral terminals and the earth terminal. The insulation resistance must be at least 2 M Ohm.

As an alternative, IEC 60598-1 Annex Q describes a test of the electrical strength with 1500 VAC (or 1,414x 1500 VDC). To avoid damage to the electronic devices this test must not be conducted.

7. CAUTION

- For five-pole wiring the neutral conductor must be connected to DA/N. This prevents 400V being applied between adjacent terminals if a different phase is used for the control input.
- Glow switches are not approved for controlling PUSH DIM. Glow switches may cause the LED driver to spontaneously switch on or off or make sudden change in the dimming value.
- The luminaire manufacturer is responsible for its own luminaire design and has to comply with all relevant safety standards.



CUPOWER Europe GmbH

Ahornweg 5a,
58675 Hemer, Germany
+49 2372-568-7570
dirk@cupower.com

Shenzhen Xiezhen Electronics Co., Ltd.

Floor 2, Building E, Taohuayuan Smart & Innovation Park,
Bao'an District, Shenzhen, China
+86 755-2781-9400
sales@cupower.com

CUPOWER North America

665 Raco drive, Lawrenceville, GA 30046 United States of America
+1 (470) 406 1566
scottr@cupower.com

Hunan Xiezhen Electronics Co., Ltd.

Building 11, Innovation Park, Linyi Road, Bailutang Town,
Suxian District, Chenzhou, Hunan, China
+86 735-265-3770
sales@cupower.com